

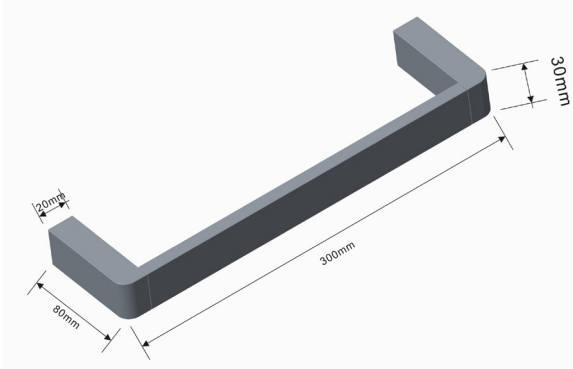

MONDRIAN NEU 300 HAND TOWEL RAIL

Product Image	Technical Specification
	

Description
<p>Mondrian Neu 300 Hand Towel Rail</p> <p>AR93612 Chrome AR93612MB Matte Black AR93612BN Brushed Nickel</p>

Additional Information
<ul style="list-style-type: none"> • 5 year warranty • Dual Fixing

