

# HYDROTHERM

## H - SERIES TOWEL RAIL

H4 Model

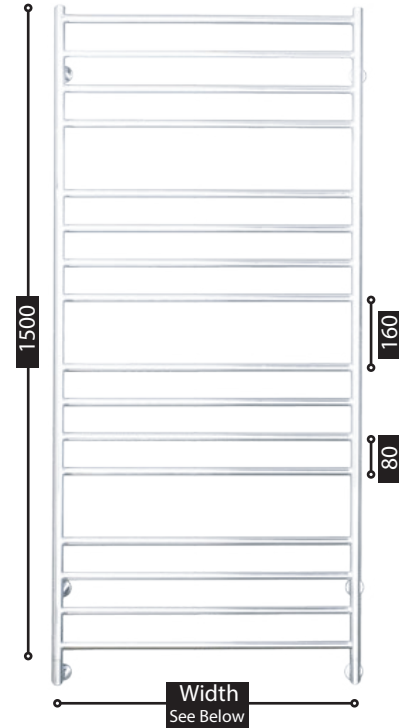

HEIGHT: 1500mm + Hardwire  
 WIDTHS: 400, 500, 600, 700  
 800mm  
 FINISH: Chrome / Powder Coat  
 WATTAGE: 100 - 300 Watt  
 TUBE DIAMETER: 25mm / 19mm

H3 Model

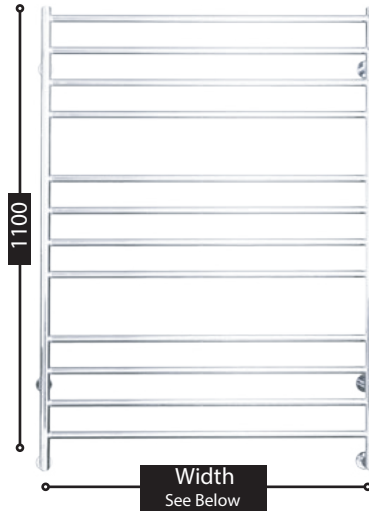

HEIGHT: 1100mm + Hardwire  
 WIDTHS: 400, 500, 600, 700  
 800mm  
 FINISH: Chrome / Powder Coat  
 WATTAGE: 100 - 250 Watt  
 TUBE DIAMETER: 25mm / 19mm

H2 Model

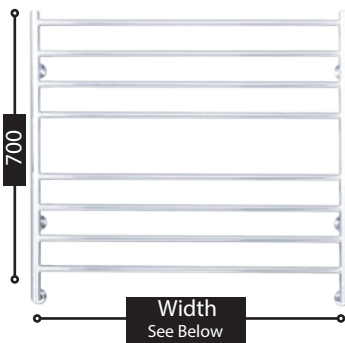

HEIGHT: 700mm + Hardwire  
 WIDTHS: 400, 500, 600, 700  
 800mm  
 FINISH: Chrome / Powder Coat  
 WATTAGE: 70 - 200 Watt  
 TUBE DIAMETER: 25mm / 19mm

### FEATURES

Replaceable Element	Heating element easily replaced
Copper Tube	Ensures ultimate thermal conductivity and radiation.
Efficient Design	Additional clustered bars provide enhanced heat transfer, ideal for drying and warming towels. Subject to sizing, can be used to provide ambient heat
Local Product	100% Australian owned and manufactured

### SPECIFICATIONS

Models	Electric / Non-Electric
Materials	Made entirely from Copper Tube with Brass Fittings
Element	Low wattage, replaceable water element
Power Cable	Bottom of unit (only) left or right hand side
Safety rating	IPX5 (allows for installation in zone 1 & 2 of bathroom)
Finish	High Polish Chrome Plate
Standards	AS/NZS:3350

**Warning:**

This appliance is not intended for use by young children or infirm persons without supervision. Young children should be supervised to ensure they do not play with this appliance

**Caution:**

Towel Rail must be installed so that the bottom rail is at least 600 mm above the floor to avoid a hazard for children. The cord extension set must be positioned so that it is not subject to splashing or ingress of moisture. The supply shall have means for disconnection with an air gap in all active conductors incorporated in the fixed wiring according to the Wiring Rules in AS/NZS 3000:2000



# H SERIES

The H Series combines sleek design and superb functionality. Its additional clustered bars provide enhanced towel warming and drying. H Series models can also be used to deliver ambient bathroom heating (subject to sizing and finish).

## MODELS:

- Electric
- Non-heated

## STANDARD FINISHES:

- High Polished Chrome
- Dulux Powdercoated Colour

## TUBE DIAMETRE:

- Vertical 25mm
- Horizontal 19mm

## STANDARD HEIGHTS :

- H2 700mm
- H3 1100mm
- H4 1500mm

## AVAILABLE WIDTHS

400, 500, 600, 700, 800

Widths measured from centre to centre of vertical tube  
Allow an extra 40mm in total when measuring total width of unit

Custom finishes and sizing available on request

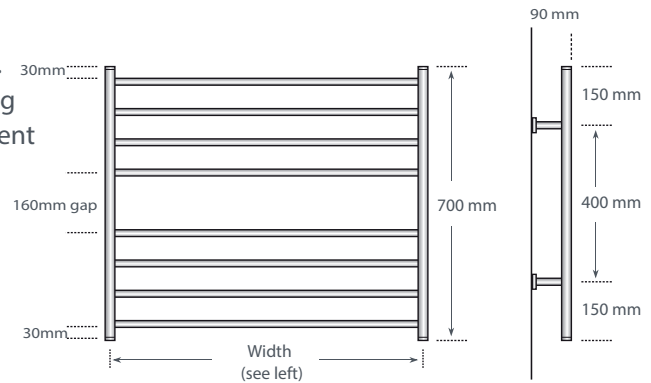

H2 MODEL

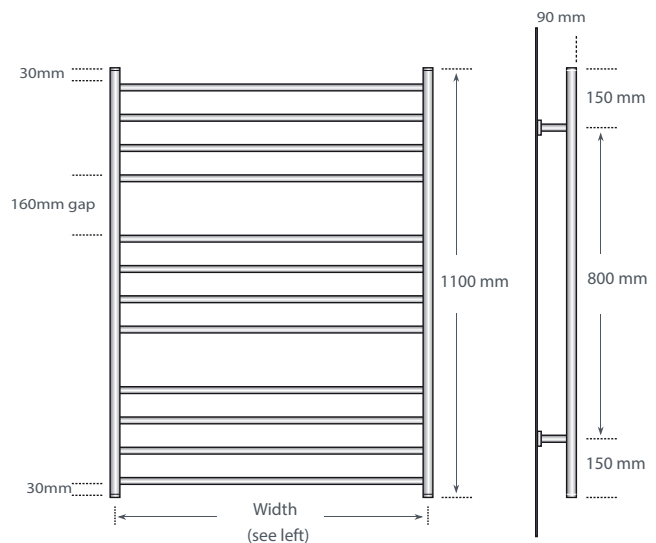

H3 MODEL

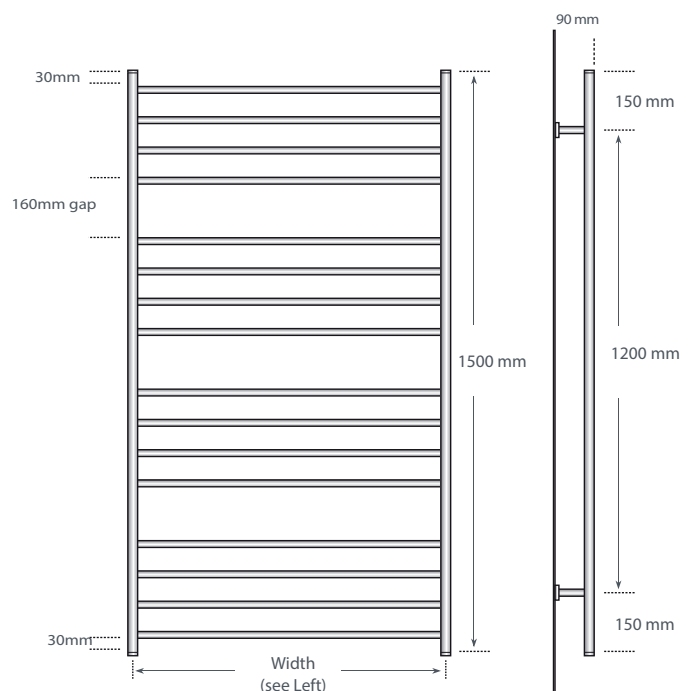

H4 MODEL

**HYDROTHERM**  
T O W E L   R A I L S

# INSTALLING BRACKETS

- Slide the WALL BRACKET ① into the BRACKET ARM ② and hold up to the wall in position.
- With a pencil, outline the WALL BRACKET ① in the desired position and remove from the wall.
- Using a pencil and the WALL BRACKET ①, mark the centre screw hole and cross it for accuracy.
- Drill a hole for the SCREW ④ and insert nylon plug into tiled wall (if applicable). Installer may choose to use alternative screws to suit the application.
- Position WALL BRACKET ① so that the GRUB SCREW hole faces directly down towards the floor and place SCREW ④ into the wall.

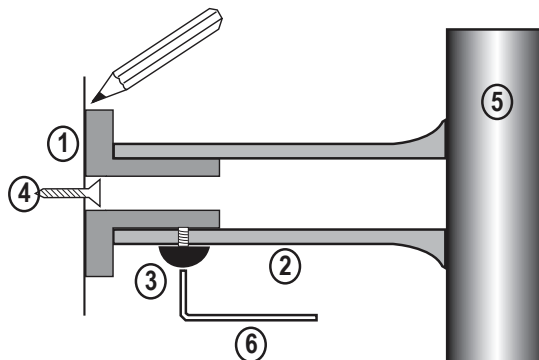

**DO NOT OVERTIGHTEN SCREW - LEAVE SLIGHT ADJUSTMENT OF THE FLANGE (SLACK) TO ENABLE MOVEMENT WHEN THE TOWEL RAIL IS POSITIONED.**

- When all of the WALL BRACKETS ① are in place, slide the TOWEL RAIL ⑤ into position towards the wall, until BRACKET ARM ② reaches the WALL BRACKET ①.
- Insert GRUB SCREW ③ through BRACKET ARM ② and into WALL BRACKET ①.
- With the ALLEN KEY ⑥ provided, tighten the GRUB SCREW until tight to ensure that towel rail stays in position.

- |   |              |   |                        |
|---|--------------|---|------------------------|
| ① | Wall Bracket | ④ | Wall Screw**           |
| ② | Bracket Arm  | ⑤ | Hydrotherm Towel Rail  |
| ③ | Grub Screw   | ⑥ | Allen Key & Grub Screw |

\*\*INSTALLER MAY CHOOSE NOT TO USE SCREW IF NOT SUITABLE FOR APPLICATION

**Hydrotherm will not accept responsibility for incorrectly installed brackets. Please read instructions carefully.**

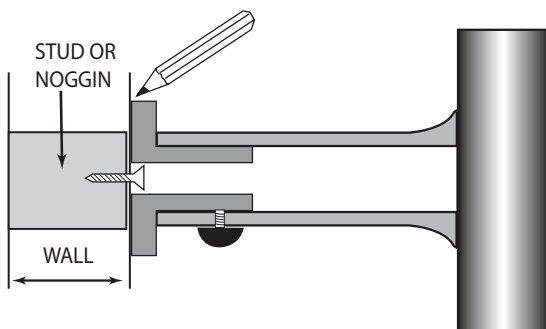

Please ensure that the measurements are taken accurately and that the screw is in a stud or noggin to provide support. Do not overtighten screws.

## WARNING

Hydrotherm take pride in the fact that all rails are individually hand made. Due to this fact some measurements may not be exact. PLEASE READ INSTRUCTIONS CAREFULLY and do not force towel rail into bracket if position of wall flange is not accurate.



**TOWEL RAILS MUST ALWAYS BE INSTALLED WITH THE ELECTRIC ELEMENT POSITIONED AT THE BOTTOM OF THE UNIT FOR CORRECT HEAT TRANSFER**



**HYDROTHERM**  
T O W E L R A I L S

## WARNING

In order to avoid hazards for young children, this appliance must be installed so that the lowest rung is at least 600mm from the floor.

# WIRING OPTIONS

The Hydrotherm H - Series Electric Towel rails come **pre-filled** with water, and with electric elements already fitted (standard on the left unless otherwise specified)

## HARD WIRED - STANDARD OPTION

(See Fig.1 & Fig.2)

The cable may be hard-wired into the wall with an element attachment. This attachment must be installed by a qualified electrician. Two attachments are provided for both the cable side, and non-cable side so to allow the unit to have a symmetrical appearance (see Fig 1).

All hard-wired elements have an IPX Rating of IP55. (IPX5) for use in wet areas. Hydrotherm also recommend all electric towel rails be connected to a timer for convenience and to prolong the life of the element.

### HARD-WIRE ATTACHMENT

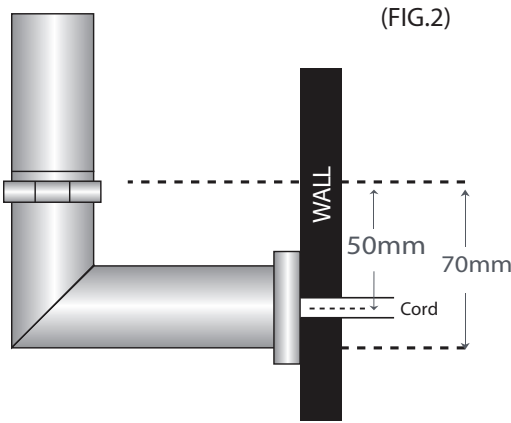

(FIG.2)

## PLUG IN OPTION - REQUEST ONLY

(See Fig. 3)

Plug is supplied with element cable (1200mm long). Cable may be cut and plug attached to required length. (See Fig 3)  
This option is only available by request.

All Hydrotherm Elements carry the following approvals.



Elements have a built in thermostat and internal cut out ensuring safety and energy efficiency.

All Hydrotherm electric elements can be supplied as 240v or 110v.

All electric elements are replaceable and can be easily changed over.

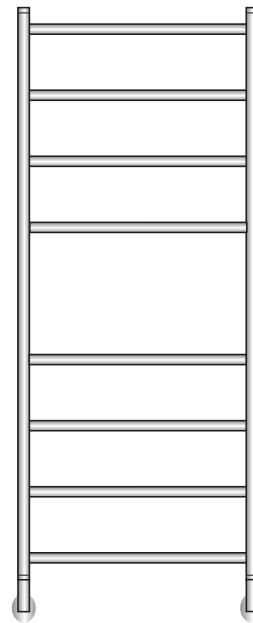

(FIG.1)

### HARD-WIRED VERSION

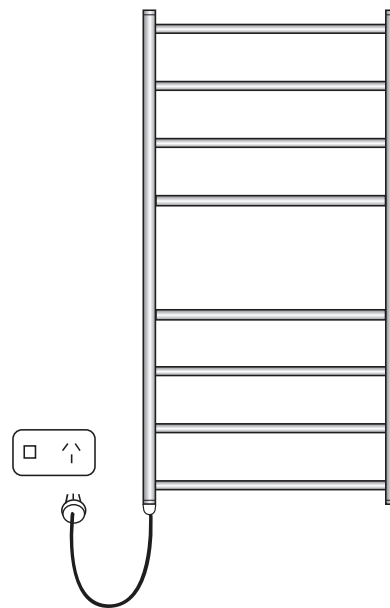

(FIG.3)

### PLUG IN VERSION

## HARD WIRING

Hydrotherm recommends that all hard-wired heated towel rails be connected to a light switch or timer.

Connecting hard-wired heated towel rails to a light switch or timer will prolong the life of the electric element and reduce energy consumption.

Hydrotherm recommend the brand HPM and the model XLP77TO, this particular unit is designed specifically for heated towel rails that is incorporated into a light switch panel.

# CHANGING ELEMENTS

To change an element from one side to the other, or to replace an old element is a very simple process. There are Four Basic S steps:

1. Remove towel rail from brackets (if already installed), and slip off Hard Wire Attachments.
2. Turn the towel rail upside down and with a spanner loosen the hex nut of the electric element. When the element is loose, unscrew it by hand. If you are changing the element from left to right or vice versa, the internal plug on the opposite side must also be removed and swapped over with the element.
3. Swap the element and screw in place. Reattach hard wire pieces.
4. Turn the towel rail the right way up, position back into brackets and refit grub screws to secure.

Please note:

Hydrotherm advise that the unit be removed from the wall and turned upside down to ensure that water does not spill. Ensure element always remains at bottom of towel rail

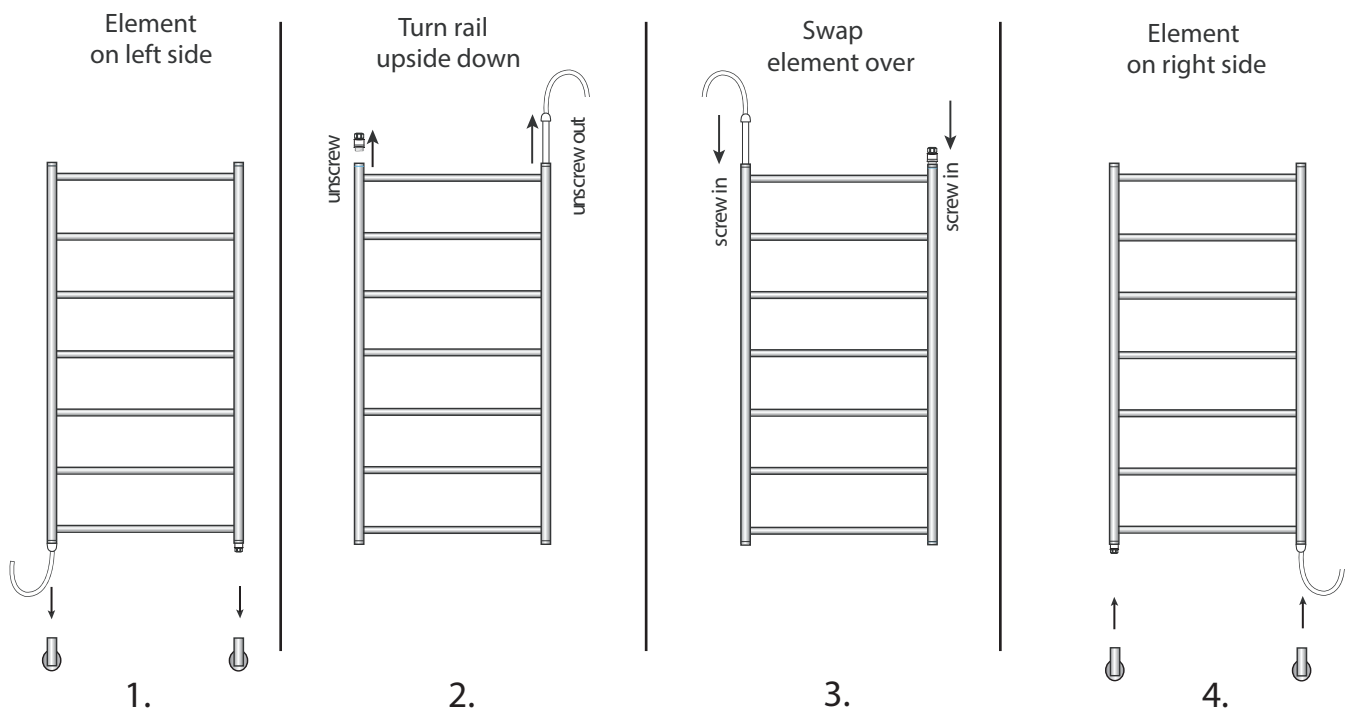

## HYDROTHERM WARRANTY

At Hydrotherm we pride ourselves on the highest quality standards of design and manufacturing. All Hydrotherm products come with a 10 year manufactures warranty on the construction and finish of our towel rails. All electric heating elements are also covered by a 3 year manufactures warranty.

10

year

Construction & Finish  
Manufacturers Warranty

3

year

Electric Element  
Manufacturers Warranty

### CLEANING RECOMMENDATIONS

This bathroom product should not be cleaned with abrasive materials eg. steel wool/scourers. Do not use any corrosive or abrasive cleaning agents containing acids or scouring agents. Bleaches can also discolour products and therefore should not be used. Damage caused by any improper treatment is not covered by the product warranty.

Disclaimer: Products in this specification manual must by regulation be installed by licensed and registered trade people. The manufacturer/distributor reserves the right to vary specifications or delete models from their range without prior notification. Dimensions are nominal measurements only. Dimensions and set-outs listed are correct at time of publication however the manufacturer/distributor takes no responsibility for printing errors.

100% Australian Made and Owned